



MEDICAL PLANT WASTE SHREDDERS

Series 1 MJ Dual Shaft Shredders

Ameri-Shred's Medical Plant Waste Shredders utilize a low speed, high torque design to easily shred medical plant waste to a desired size.

MEDICAL PLANT WASTE INCLUDES:

- Medicinal Plants
- Vegetative Plants
- Plant Root Balls
- Plant Stems & Stalks
- Plant Leaves
- Rockwool
- Hemp Plant Waste
- Failed Clones
- Harvest Waste



Features & Options

BEARING PROTECTION

Shredded contaminants are prevented from reaching the bearings through the use of false walls and seals.

INDIVIDUAL CLEANING FINGERS

Reduces wrapping and material packing between the cutters, while being easy to remove and adjust.

CUSTOM LAYOUTS

System Engineers will work to ensure the shredder and supports fit seamlessly into your system.

CUTTER DESIGN

The number and length of hooks, as well as cutter width are selected to maximize throughput.

AUTO SHAFT REVERSAL

Improves online reliability by reorienting material to grab, preventing overfeeding, and protecting against damage from unshreddable objects.

HIGH TORQUE, LOW SPEED TECHNOLOGY

Less downtime, noise and dust emission than high speed shredders.

MEDICAL PLANT WASTE SHREDDERS

Series 1: MJ Dual Shaft Shredders

SPECIFICATIONS:

MODEL	HP	CUTTER WIDTH	CUTTING CHAMBER	LBS. PER HOUR
MJ-21001	1	5/16"	8" W x 10" L	100
MJ-21003	3	5/16"	12" W x 12" L	300
MJ-21005	5	5/16"	12" W x 12" L	500

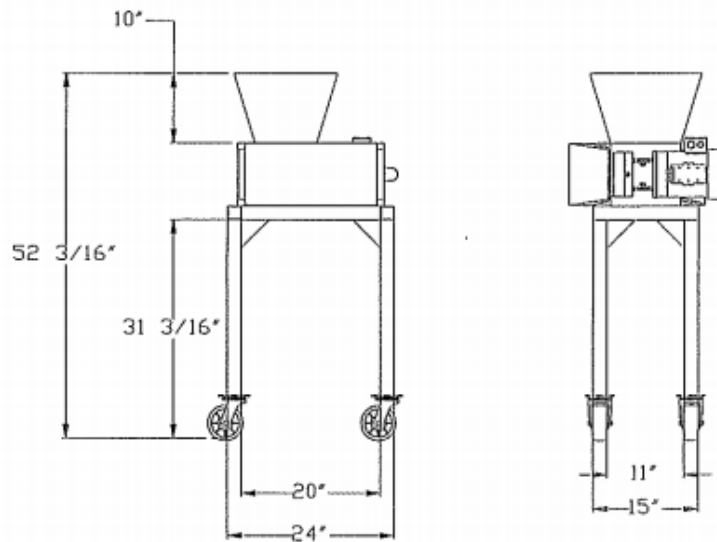
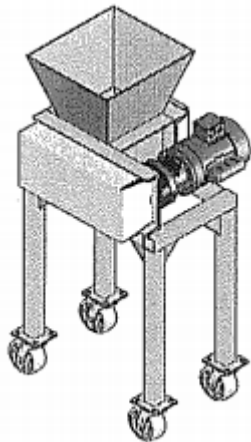
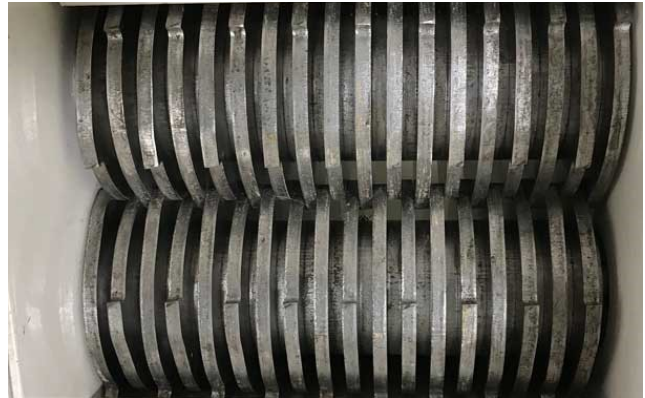

SPECIFICATIONS:

VOLTAGE:	ELECTRIC DRIVE
120V	MJ-21001 ONLY
220V - 1 PHASE	MJ-21001 / 21003 / 21005
ANY 3 PHASE	MJ-21001 / 21003 / 21005
CUTTER MATERIAL	4140 HT, AR500
AUTO REVERSE	INCLUDED
HOUR METER	INCLUDED
POWER LOCK OUT	INCLUDED
3 CUBIC FOOT BIN	16" W X 19" L X 17" H
SAFETY DOOR	INCLUDED

