



E-SCRAP & E-WASTE SHREDDERS

DS-60, DS-80 & DS-100

Ameri-Shred's E-Scrap & E-Waste Shredders utilize a low speed, high torque dual shaft design to easily shred a wide range of materials to a desired size.

Materials INCLUDE:

- E-Scrap
- Hard Drives
- Circuit Boards
- Data Tapes
- Reel-to-Reel Tapes
- PC's
- Printers
- Tablets
- CD's & DVD's
- Laptops

E-Scrap



Hard Drives



Circuit Boards



Data Tapes

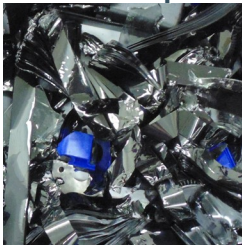

Features & Options

SMALL FOOTPRINT

Right angle drives allow for a compact design, minimizing floor space.

BEARING PROTECTION

Shredded contaminants are prevented from reaching the bearings through the use of false walls and seals.

INDIVIDUAL CLEANING FINGERS

Reduces wrapping and material packing between the cutters, while being easy to remove and adjust.

CUSTOM LAYOUTS

System Engineers will work to ensure the shredder and supports fit seamlessly into your system.

CUTTER DESIGN

The number and length of hooks, as well as cutter width and material are selected to maximize throughput at the required shred size.

AUTO SHAFT REVERSAL

Improves online reliability by reorienting material to grab, preventing overfeeding, and protecting against damage from unshreddable objects.

HIGH TORQUE, LOW SPEED TECHNOLOGY

Efficiently process bulk fed, tough to shred materials. Less downtime, noise and dust emission than high speed shredders.

E-SCRAP & E-WASTE SHREDDERS

60 - 100 HP Standard 50" L. X 32" W. Cutting Chamber

MODELS: DS-60, DS-80 & DS-100

DRIVE	ELECTRIC
NUMBER OF MOTORS	2
HORSEPOWER	60 HP - DUAL 30 HP MOTORS 80 HP - DUAL 40 HP MOTORS 100 HP - DUAL 50 HP MOTORS
VOLTAGE	230/460V - 3 PHASE
CUTTER THICKNESS (nominal)	3/4", 1", 1 1/2", 2", 4"
CUTTER MATERIAL	4140 HT, AR500, HARDFACED
CUTTER DIAMETER	14"
HEX SHAFT SIZE	5 3/4"
CUTTING CHAMBER (W X L)	50" W X 32" L.
WEIGHT	8500 Lbs.

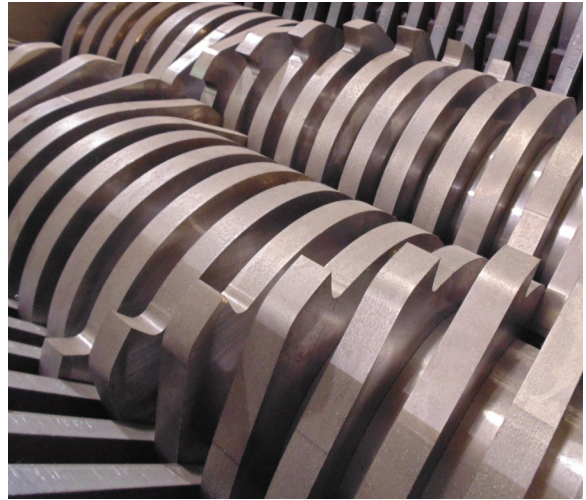

Hopper and Stand

ARE CUSTOM DESIGNED PER APPLICATION

Layout drawings are just a starting point

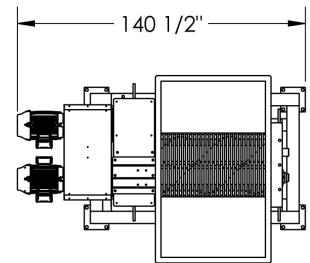
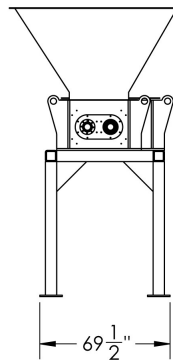
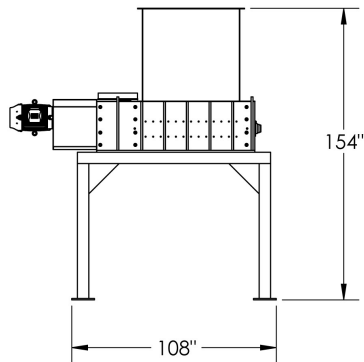

Let us provide you with a TURNKEY SOLUTION

Our team of experienced salespeople and system engineers take a special interest in what you need to shred. Everything from the cutter profile to the system layout is carefully considered to ensure you obtain the shred size and throughput you need. Our goal is to maximize the efficiency of your process with a shredder that fits seamlessly with your other equipment.

