

Horizon

TRIMMING

iCE TRIMMER HT-300

NEXT GENERATION BOOK TRIMMER WITH HIGHER PRODUCTIVITY AND MORE AUTOMATION



BENEFITS

HIGH SPEED

New features such as auto book thickness measurement increase the maximum production speed up to 300 books/stacks per hour (4 books/stack x 3 = 1,200 bph).

LABOR SAVINGS

The HT-300 can be connected with Horizon perfect binders and output conveyers for in-line book production efficiency.

UNIQUE TRIMMING FEATURE

Differentiating corner cut capability. The rotary table in the trim section enables not only three-side trimming but also finishing in a variety of shapes.

CONFIGURATION FLEXIBILITY

Multiple options* for the feeder and delivery unit allow for flexible machine configurations depending on your needs.

* For the feeder: stack or pusher in feed
For the delivery unit: delivery stacker or conveyor (front/side)

SPECIFICATIONS.



MANAGE YOUR BINDERY WITH HORIZON'S BINDERY CONTROL SYSTEM

The ICE Series can be enhanced with JDF workflow from upstream to postpress using the Horizon pXnet Bindery Control System / ICE LINK. ICE LINK is the next generation of pXnet.



(Top View)

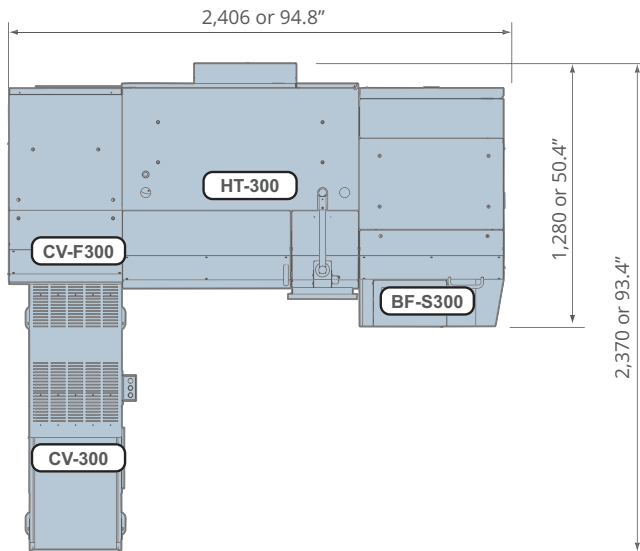

(Side View)

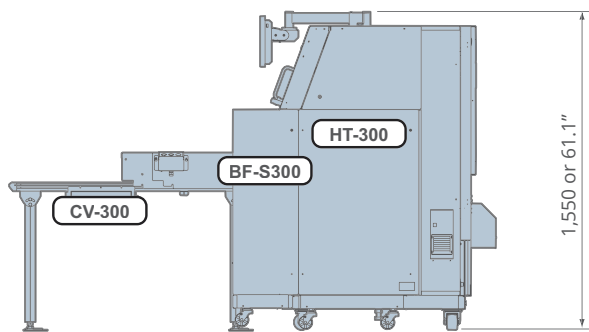

HT-300

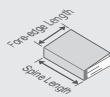
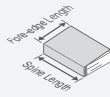
Untrimmed Book Size Spine	 <p>Length x Fore-edge Length</p>	<p>Standard Tables</p> <p>Table A for portrait: Max. 350 × 235 mm or 13.775" × 9.250" Min. 277 × 206 mm or 10.910" × 8.115"</p> <p>Table B for portrait: Max. 350 × 235 mm or 13.775" × 9.250" Min. 204 × 136 mm or 8.035" × 5.355"</p> <p>Table C for landscape: Max. 320 × 350 mm or 12.595" × 13.775" Min. 211 × 275 mm or 8.310" × 10.830"</p> <p>Table K for A6: Max. 320 × 219 mm or 12.595" × 8.620" Min. 152 × 107 mm or 5.985" × 4.215"</p>
Finished Book Size	 <p>Length x Fore-edge Length</p>	<p>Standard Tables</p> <p>Table A for portrait: Max. 340 × 230 mm or 13.385" × 9.055" Min. 273 × 204 mm or 10.750" × 8.035"</p> <p>Table B for portrait: Max. 340 × 230 mm or 13.385" × 9.055" Min. 200 × 134 mm or 7.875" × 5.280"</p> <p>Table C for landscape: Max. 340 × 305 mm or 13.385" × 12.005" Min. 207 × 273 mm or 8.150" × 10.750"</p> <p>Table K for A6: Max. 305 × 217 mm or 12.005" × 8.540" Min. 148 × 105 mm or 5.830" × 4.135"</p>
Trim Width	<p>Max. 99.9 mm or 3.930" Min. 2 mm or 0.080" "0" can be entered (no trimming).</p>	
Trim Height	<p>Max. 51 mm or 2.005" Min. 1 mm or 0.040"</p>	
Clamp System and Pressure	<p>Servo motor 1 through 7 kN (100 through 700 kgf)</p>	
Book Stack Height	<p>BF-S300 Suction Feeder 300 mm or 11.81"</p>	
Production Speed	<p>BF-S300 Sucker Feeder When trimming one book: Max. 160 through 300 books per hour When trimming multiple books: 280 through 590 books per hour</p> <p>BF-P300 Pusher Feeder When trimming one book: Max. 160 through 300 books per hour When trimming multiple books: (160 through 300 × number of stacked books) per hour</p>	
Voltage/Frequency	<p>200-240 V, 50 or 60 Hz (400 V, step down to 200 V by transformer)</p>	
Machine Dimensions	<p>When the BF-S300 sucker feeder is connected: 2,406 (W) × 1,280 (D) × 1,550 (H) mm or 94.7" (W) × 50.4" (D) × 61.0" (H)</p> <p>When the BF-P300 pusher feeder is connected: 2,406 (W) × 3,187 (D) × 1,550 (H) mm or 94.7" (W) × 125.5" (D) × 61.0" (H)</p> <p>Note that the dimensions of the CV-300 + CV-S300 side conveyor, CV-300 + CV-F300 front conveyor are not included</p>	

Horizon

Horizon International, Inc.

510 Kuze Ooyabu-cho, Minami-ku,
Kyoto, 601-8206, Japan
Phone : +81-75-934-6700
Fax : +81-75-934-6708
www.horizon.co.jp

Distributed by

STANDARD

Standard Finishing Systems

10 Connector Road, Andover,
MA 01810
Phone : 877-404-4460 / 978-470-1920
Fax : 978-470-2771
www.standardfinishing.com

MORE AT HORIZON.CO.JP

