

Morgana Systems Ltd
3909 Upland Way, Marietta
GA 30066 Georgia
USA
Tel: 866 463 5060
Fax: 770 565 6163
www.morganausa.com
morganausa@comcast.net



AutoCreaser

A fast and effective solution to the old cracking problem.

The AutoCreaser, made in the UK by Morgana, provides the complete solution to the problem of cracking that occurs when folding digitally printed output. It is equally effective in dealing with conventionally printed card, laminates or cross-grained stock.

Before Morgana launched the AutoCreaser, printers and finishers faced with these problems had two choices. The first was to use a platen or cylinder press. Effective, but very slow to set up and demanding high skill levels. The second involved the use of rotary scoring, which almost inevitably damages the material, resulting in white show through on the spine of the folded document.

Creasing versus Scoring.

Traditional rotary scoring machines use circular blades that are in constant motion as the stock passes through them. This creates a ploughing action that actually cuts through the top fibres of the paper or card in order to create a score. Inevitably this weakens the paper and encourages cracking. In contrast, the Morgana AutoCreaser employs a unique creasing rule and matrix as illustrated overleaf, that eliminates tearing and, therefore, cracking.

Key Product Features

- **Fast & easy to setup**
- **Fully automatic**
- **Up to 16 creases per sheet**
- **Takes stock up to 0.015" (approx 150lb cover)***
- **Rule and matrix guaranteed for life**
- **5500 sheets per hour**
- **Memory for storing repeat jobs**
- **Adjustable crease depth & square**
- **Perforating as standard**
- **Crease without cracking**

The AutoCreaser is a fully automatic, suction fed device, which is infinitely faster to set up than a platen and is supremely easy to use. It takes a maximum sheet size of 27.5" x 12.9" and takes stock up to 0.015" (approx 150lb cover)* including laminated material. It performs 5500 creases per hour on 8.5" x 11".

The AutoCreaser can also be programmed to make 16 creases in a single pass with a 0.15" minimum distance between creases. Individual crease adjustments can be made in 0.003" increments without affecting other crease positions. For repeat work it will memorise up to 9 pre-set applications.



The AutoCreaser works by using a creasing rule and matrix action that applies several tonnes of pressure to weaken the fibres of the paper. Unlike a scorer, however, this does not tear the surface, so there is no white show-through even when the fold is made in an area of solid colour.

The AutoCreaser is fully mobile with a small footprint. A single operator can feed the machine and offload the catch tray or optional jogger.

Morgana use stepping motor technology to accurately position the substrate before creasing and we use the same technology with the creasing action. This gives total and consistent accuracy during operation. With thousands of mechanism's installed throughout the world our creasing technology is unparalleled in both performance and longevity which is why we offer a life long guarantee on the rule and matrix.

The AutoCreaser has a Head-up Display for greater ease of use. This is particularly intuitive as it provides the operator with a series of prompts which are actioned by a single controller. These include positioning of the creases, setting the speed of the machine, storing jobs and counting facility.

AutoCreaser

A fast and effective solution to the old cracking problem.



technical specifications

Maximum sheet size	27.5" x 12.9"
Minimum sheet size	8.2" x 5.5"
Maximum paper thickness	0.015" (approx 150lb cover)* including laminated material
Minimum paper thickness	0.004" (approx 20lb bond)*
Maximum number of creases per sheet	16
Maximum number programmed applications	9
Minimum repeat crease distance	0.03" (depending on paper weight)
Minimum crease distance from lead edge	0.19"
Minimum crease distance from tail edge	0.59"
Speed per hour (8.5" x 11")	5500 sph
Dimensions	L 45.9" x W 17.9" x H 38.9"
Weight	264lb
Power requirement	240v 50/60hz
Options	Narrow creasing blade, Narrow sheet guide

Note: the production speed varies according to material size and the number of creases on the sheet

Creasing rule and matrix. The AutoCreaser uses an identical mechanism to that on the more expensive AutoCreaser Pro 33 and DocuMaster Pro and is guaranteed for life. With thousands of these mechanisms installed throughout the world our creasing technology is unparalleled in both performance and longevity.

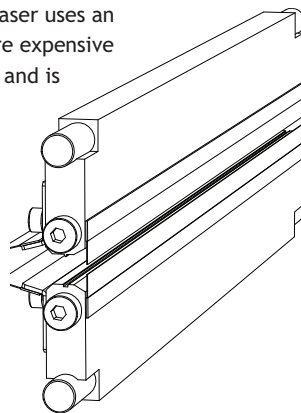

*Disclaimer

As part of our continued product improvement plan, specifications and information published here are subject to change without notice.

All specifications are dependent on application, type of stock, temperature, RH and print engine used.

Specifications quoted were measured on uncoated and unprinted stock.

E & OE.